

Fiber Optic Laryngoscopes

Recommended Cleaning, Sterilization and Instructions for Use



Fiber Optic Features

These operating instructions pertain to both König brand integrated and non-integrated (Green System) Fiber Optic Laryngoscopes. These instructions should be followed to ensure the longevity and durability of this product. Please inspect all components before use to confirm all items are present and in perfect working condition.

Medline fiber optic laryngoscope blades are manufactured from a high quality AISI 303/304 stainless steel which is highly resistant to corrosion and conforms to ISO 7376.

Green System fiber optic laryngoscope blades are removable and interchangeable with other blades of the same size. By unscrewing the locking side screw as shown in Figure 1, the light guide can be disengaged and removed for cleaning, repairs or replacement.

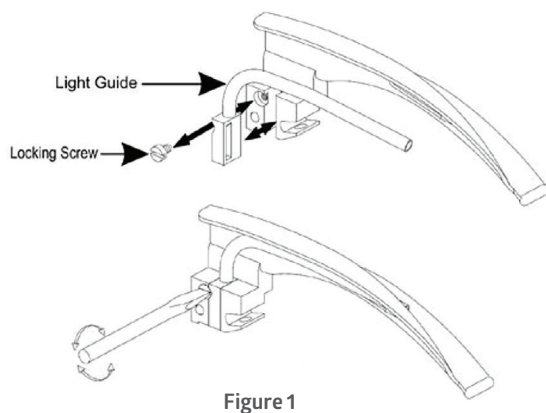
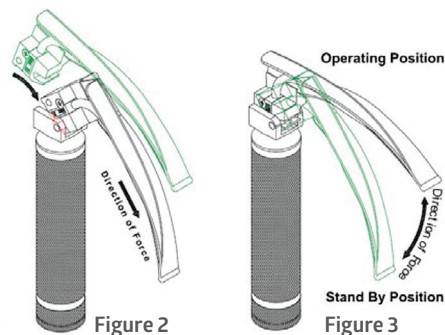

Figure 1

The integrated fiber optic blades are built with an integrated fiber optic bundle with no cavities, thus allowing for easy decontamination. Integrated fiber optic blades are maintenance free and may be sterilized via autoclave up to 134° C/5 min approximately 4,000 times.

Operating Instructions

1. Engage the blade by aligning the slot of the blade on to the hook pin of the handle and apply a sufficient force (1/4–1 lb) as shown in Figure 2.
2. Apply force upward to bring the blade into operating position as shown in Figure 3.
3. To bring the blade into standby position apply force downward as shown in Figure 3.



Light Guide Replacement Procedure

1. Remove locking screw with a screwdriver as shown in Figure 1.
2. Pull out the green block and slide out the light guide.
3. Fix new light guide of similar size and replace the locking screw.
4. Be sure the screw is properly tightened.

Caution: Great care should be taken while performing this procedure to avoid structural damage to the fiber blade.

Lamp Replacement Procedure for Xenon F.O. Handle

4. Unscrew the head from the barrel counterclockwise as shown in Figure 4.
5. Remove the lamp from the head.
6. Replace the new lamp.
7. Screw the head clockwise to the barrel.

Attention: Always try to keep the lens of the lamp clean for better performance.

NOTE: LED handles do not require replacement.

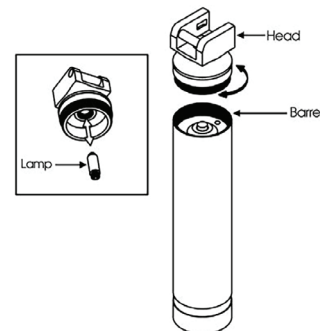
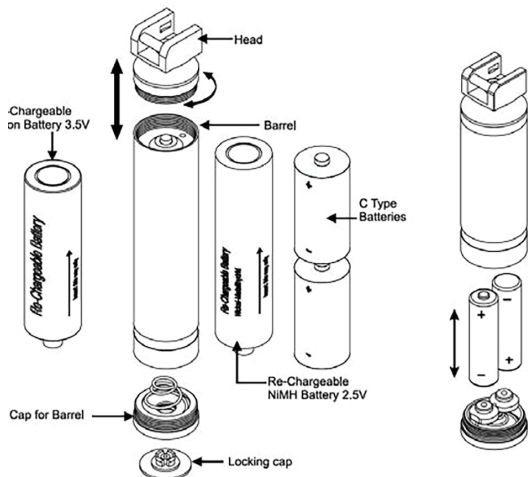

Figure 4

Battery Replacement Procedure



*2.5V Xenon and LED handles can be used with dry batteries as well as rechargeable batteries.

NOTE: In accordance with local regulations, rechargeable batteries should be disposed of as an electronic device separately.

Cleaning Procedure

Attention: Remove batteries before cleaning, high level disinfection or sterilization of the laryngoscope system.

Blades and Handles

1. Immediately after use, the laryngoscope system should be rinsed under cool running tap water until all visible soil is removed. Ensure that all hard to reach areas are flushed with the running tap water.
2. Immerse the sealed laryngoscope system in a presoak enzymatic cleaner solution, prepared in accordance to the manufacturer's recommendations for a minimum of two (2) minutes.
3. Remove device from enzymatic cleaner solution and rinse with lukewarm running tap water for a minimum of one (1) minute to remove all residues and visible soils.
4. Immerse the device in enzymatic detergent. Remove bottom cap and brush items thoroughly using a soft bristle brush, ensuring all visible soils are removed.
5. Rinse under running reverse osmosis/deionized (RO/DI) water to remove detergent residuals.
6. Dry with a lint-free cloth or filtered pressurized air.

WARNING! Ultrasonic cleaning is strictly prohibited.

Disinfection

Soaking in solutions or thermo chemically in a washer sterilizer up to 65°C max may be used to perform disinfection. Manufacturer's instructions regarding duration and concentration of solutions should be strictly adhered. After disinfection, rinse thoroughly in RO/DI water and dry with a lint-free cloth.

Cold Soak Solution

To achieve a high-level disinfection, Cidex OPA or 2.4% Glutaraldehyde solution may be used according to the manufacturer's instructions. Dry with lint-free, clean cloth or filtered pressurized air. Reassemble all parts, load handle with batteries and test the system for proper function. If not functional, review the battery lamp testing instructions below.

WARNING! Do not immerse blades in Bleach, Betadine or Potassium Hydroxide solutions. Doing so will cause severe damage to the instruments. Avoid metal to metal contact during and after soaking.

Xenon and LED Handles

Xenon and LED handles may withstand the same cold soak solution outlined in the blade section. The batteries and lamp must be removed prior to disinfection/sterilization. Battery handles may withstand exposure to ethylene oxide. The Lamp may be cleaned with a cotton ball dampened in alcohol (IPA).

Note: The LED handles may be autoclaved/sterilized without removing the LEDs.

Attention: Do not allow excess fluid to seep into electrical contact; batteries must be removed before cleaning and sterilization.

Sterilization

Before performing any of the procedures described below, the blade and handle should be cleaned as described in the cleaning procedure.

Note: It is recommended to remove the fiber optic light guide from Green System blades before sterilization as it may adversely affect the polishing of the fiber and decrease light output.

Gas Sterilization

Gas sterilization by ethylene oxide may be used up to a maximum temperature of 65° C and 8 PSI.

Cycle Type	Parameter	Minimum Set Point
Pre vacuum	Exposure Temp	270°F (132°C)
	Exposure Temp	4 minutes
	Dry Time	20 minutes

Cycle Type	Parameter	Minimum Set Point
Gravity Displacement	Exposure Temp	250°F (121°C)
	Exposure Temp	30 minutes
	Dry Time	15 minutes

NOTE: Do not exceed a temperature of 135°C and a pressure of 28 PSI.

WARNING! Flash autoclaving and hot air sterilization should be avoided as these processes will damage the instrument.

NOTE: The above listed sterilization guidelines, provided by Medline Industries, LP are intended as procedures compatible with specific materials. Sterilization must be performed to approved hospital protocol. Medline Industries, LP can not guarantee sterility. This will be validated by the hospital and or sterilization equipment manufacturers.